

Installation and Maintenance Instruction Manual

BRONZE SERIES TRANSMITTERS

In the following configuration:

- PB55 Process pressure and level transmitter BRONZE SERIES
- CB55 Cleanline pressure and level transmitter BRONZE SERIES



PB55



CB55

Table of contents:

1	General remarks.....	4
1.1	Purpose of this Manual.....	4
1.2	Symbols.....	4
1.3	Limits of liability.....	4
1.4	Copyright.....	4
1.5	Warranty.....	4
1.6	Precautions and warnings.....	4
1.7	Manufacturer's address, customer services.....	5
2	Safety.....	5
2.1	General sources of hazards.....	5
2.2	Use in accordance with intended purpose.....	5
2.3	Operator's responsibility.....	5
2.4	Staff qualifications (target group assessment).....	6
2.5	Signs/Safety markings.....	6
2.6	Environmental protection.....	6
3	Certificates/ details.....	6
3.1	CE / EMC – Rules.....	6
3.2	Traceability year of manufacturing.....	6
4	Technical data.....	6
4.1	Specifications.....	6
4.2	External Load.....	7
5	Labeling.....	7
6	Construction and function.....	7
6.1	Process transmitter BRONZE SERIES PB55.....	7
6.2	Cleanline transmitter BRONZE SERIES CB55.....	8
6.3	Barometric reference.....	8
6.4	Accessories.....	8
7	Transport.....	9
7.1	Safety.....	9
7.2	Transport inspection.....	9
7.3	Storage.....	9
8	Assembly/Installation.....	9
8.1	Installing Weld-On Nipple.....	9
8.2	Installing Process Transmitter BRONZE SERIES PB55 (with weld-on nipple).....	9
8.3	Installing Cleanline Transmitter BRONZE SERIES CB55 (with weld-on nipple).....	9
8.4	Mounting Position.....	10
8.5	Mounting Position Effect.....	10
8.6	Calibration.....	10
8.7	Wiring.....	10
8.8	Digital local indicator(optional).....	11
8.9	Subsequent relocation of the transmitter (by the customer).....	13
9	Servicing.....	13
9.1	Safety.....	13

9.2	Check on function, and recalibration	13
9.3	Cleaning and maintenance	13
10	Faults	13
10.1	Safety.....	13
10.2	Conduct in the event of faults	13
10.3	Fault table	13
10.4	Conduct following fault rectification	14
11	Removal, disposal.....	14
11.1	Safety.....	14
11.2	Removal.....	14
11.3	Disposal	14
12	Appendix	14
12.1	Data sheet for BRONZE SERIES PB55 and CB55.....	14
12.2	Declaration of conformity model PB55 and CB55	15

1 General remarks

1.1 Purpose of this Manual

This Operating Manual contains fundamental and essential advice to be followed for the installation, operation and servicing of the device. It must be read without fail before assembly and start-up of the device by the fitter, the operator and the specialist personnel responsible for the device. This Operating Manual must be available at the point of use at all times.

The following sections about general safety information and also the following specific advice regarding the intended purposes (Section 2), and through to disposal (Section 11) contain important safety information which, if not followed, may result in risks for people and animals, or to property and buildings.

1.2 Symbols



Warning!

This indicates a possibly hazardous situation where failing to follow advice may result in risks to people, animals, the environment and buildings.



Information!

This emphasizes key information for efficient, fault-free operation.

1.3 Limits of liability

Failure to respect this safety information, the envisaged uses or the limit values relating to use indicated in the technical data for the device may result in risk or to injury to people, the environment or the plant.

Claims for compensation for damage against the device supplier are excluded in such an eventuality.

1.4 Copyright

This Operating Manual may only be copied and passed on as a complete document with the special permission of the publisher.

1.5 Warranty

For the product described here, we offer a warranty pursuant to Section 6 Guarantee in Respect of Defects in our *General Terms and Conditions* of Delivery and Payment.

1.6 Precautions and warnings

- Check if the specifications of the transmitter meet the needs of the process conditions.
- When the BRONZE SERIES PB55 or CB55 is used as a level transmitter, be aware of the place where the transmitter is mounted. Here are some suggestions:
 1. DO NOT mount a level transmitter in- or near filling or discharging pipes.
 2. In case of automatic cleaning systems or hand cleaning: never point the water jets on the diaphragm, take necessary steps to avoid this. Guarantee will not be granted.
- When the BRONZE SERIES PB55 or CB55 is used as a pressure transmitter, be aware of the following points:
 1. Rapid closing valves in combination with high flow velocity will cause water hammer(spikes) and can destroy the transmitter. DO NOT mount a transmitter near such valves, always a few pipe bends away up or down stream (avoid suction).
 2. Install a pressure transmitter a few pipe bends away from pumps, as well on the suction or pressure side of the pump
- WELDING INFORMATION: When using the BRONZE SERIES with weld on nipple, the welding information in Section 8 must be followed exactly. This is very important to prevent distortion of the weld-on nipples. It also prevents the screw thread from the Cleanline transmitter CB55 (M56 x 1.25) from being deformed.
- The diaphragm of the transmitter is protected with a special protection cap. Protect the diaphragm until installation takes place, to prevent damaging of the diaphragm.
- As soon as the wiring is brought inside through the cable gland and connected to the terminal board, make sure the cable gland is tightly fixed, so that moisture cannot enter into the electronic housing.

- NEVER unscrew the venting (See Section 6 Part No.3), because it is especially designed to prevent moisture from entering into the electronic housing. If the ambient conditions are very wet, we advise to use a venting through the cable. A special vented cable can be delivered on request.
- Avoid high pressure water-jets pointed at the venting.
- The covers must be fully engaged, so that moisture cannot ingress into the electronic housing. The covers must only be capable of being released or removed with the aid of a tool.

1.7 Manufacturer's address, customer services

Ashcroft Instruments GmbH
Max-Planck-Strasse 1
D-52499 Baesweiler. Germany

Tel.: +49 (0) 2401/808-888
Fax.: +49 (0) 2401/808-999
E-mail: customer.service@ashcroft.com
Web: www.ashcroft.eu

2 Safety

2.1 General sources of hazards

Pressure transmitters are pressurized parts where failure can result in hazardous situations. The selection of pressure transmitter should be made in accordance with the applicable national and international standards.

2.2 Use in accordance with intended purpose

The devices are only to be used for the intended purpose as described by the manufacturer.

The BRONZE SERIES transmitters are solid-state pressure- and level transmitters based upon a bridge resistive silicon sensor, with a very high burst pressure. Pressure of the medium applied on a sensor element, creates a very small deflection of the silicon substrate and bridge network. The resulting strain in the silicon resistors causes a change in the bridge resistance that is proportional to the pressure applied. The transmitter electronics detects this change in bridge resistance and converts it into 4-20 mA. The amplifier system is based on a single Integrated Circuit, which ensures a perfect linearity in the 4-20 mA output.

The devices are used for pressure measurements in process or sanitary applications. For each use scenario, the corresponding set-up regulations must be respected.

2.3 Operator's responsibility

Safety instructions for proper operation of the device must be respected. They are to be provided by the operator for use by the respective personnel for installation, servicing, inspection and operation. Risks from electrical energy and from the released energy of the medium, from escaping media and from improper connection of the device must be eliminated. The details for this are to be found in the corresponding applicable set of regulations, such as DIN EN, UVV (accident prevention regulations) and in sector-specific instances of use (DVGW, Ex-. GL, etc.) the VDE guidelines and the regulations supplied by local utilities companies.

The device must be taken out of service and secured against inadvertently being restarted, if the presumption is that risk-free operation is no longer possible (see Section 10: Faults).



Conversion works or other technical alterations to the device by the customer will violate the approval for hazardous area and are not permitted. This also applies to installation of spare parts. Possible conversions or alterations may only be carried out by the manufacturer.

The operational safety of the device is only guaranteed where it is used for its intended purpose. The specification of the device must be adapted to the medium used in the plant. The limit values indicated in the technical data must not be exceeded.

The safety information detailed in this Operating Manual, existing national regulations for accident prevention, and the operator's internal regulations regarding working, operations and safety must be respected.

The operator is responsible for all specified servicing, inspection and installation works being carried out by authorized and qualified specialists.

2.4 Staff qualifications (target group assessment)

The device may only be installed and started up by specialist staff who are familiar with installation, start-up and operation of the product.

Specialist staff are people who are able to assess the work assigned to them on the basis of their specialist training, their knowledge and experience and their knowledge of the relevant standards, and can identify possible risks.

For devices in explosion-protected configuration, these staff must have been trained or instructed in, or be authorized for, working on explosion-protected devices in potentially explosive plants.

2.5 Signs/Safety markings

The pressure transmitter and its surrounding packaging carry markings. These markings show the article number, measurement range and manufacturer. The pressure transmitter can be provided with additional signs and safety markings advising on special conditions:

- Advice on the filling liquid
- Advice on calibration
- Safety advice for flush diaphragm

2.6 Environmental protection

This device contains a small amount of silicone oil or a foodgrade oil(Neobee M20). The provisions set out in the REACH regulation on production and use of chemicals are to be respected, and the relevant safety data sheets from the manufacturers of the chemicals are available on our website for download.

3 Certificates/ details

3.1 CE / EMC – Rules

All BRONZE SERIES transmitters are manufactured in accordance with the RFI / EMC directives and comply with the CE standard. All transmitters are fitted with RFI filters, which provide optimum, trouble-free operation. Our products are in conformity with EMC-Directive 2004/108/EC based on test results using harmonized standards.

3.2 Traceability year of manufacturing

The year of manufacturing of the transmitter can be traced as follows: take the first three numbers from the serial number that is engraved in the transmitter and add 1908 to it.

For example: if the serial number is 10509426. The year of manufacturing is 1908 + 105 = 2013. For older transmitters, for example with serial number 9302123, the first two numbers must be add to 1908.

4 Technical data

4.1 Specifications

Manufacturer	Ashcroft Instruments GmbH			
Instrument	BRONZE SERIES PB55/CB55			
Output	4-20 mA			
Power Supply	Standard : 12 – 36 Vdc			
Accuracy	0,2% of adjusted span			
Ranges ¹	Code	Adjustable span ranges		Max. overpressure
BRONZE SERIES transmitters PB55/CB55	P4BR	0-0,1 bar	0 - 0,4 bar	6,4 bar
	P7BR	0-0,4 bar	0 - 0,7 bar	6,4 bar
	1P5BR	0-0,7 bar	0 - 1,5 bar	10,5 bar
	4BR	0-1,0 bar	0 - 4,0 bar	16 bar
	10BR	0-2,5 bar	0 - 10 bar	30 bar
	16BR	0-7,5 bar	0 - 16 bar	60 bar
	50BR	0-16,0 bar	0 - 50 bar	120 bar
	80BR	0-40 bar	0 - 80 bar	200 bar
Process Temperature ¹ Process transmitter BRONZE SERIES PB55	-20 °C to +80 °C (-4 °F to 176 °F)			

Process transmitter BRONZE SERIES PB55 Cable	-20 °C to +80 °C (-4 °F to 176 °F)
Cleanline transmitter BRONZE SERIES CB55	-20 °C to +100 °C (-4 °F to 212 °F)
Cleanline transmitter BRONZE SERIES CB55 Cable	-20 °C to +80 °C (-4 °F to 176 °F)
Temperature effect	0,015% / K
Ambient Temperature	-20°C to 70°C (-4 °F to 158 °F)
Protection grade	IP66 IP68(for PB55 Cable and CB55 cable submersed parts)
Material	Housing: AISI 304 "wetted" parts: AISI 316 L

- For higher process temperatures please use BRONZE SERIES CB55 with option HT and specify the exact process temperature, or contact Ashcroft Instruments GmbH.

4.2 External Load

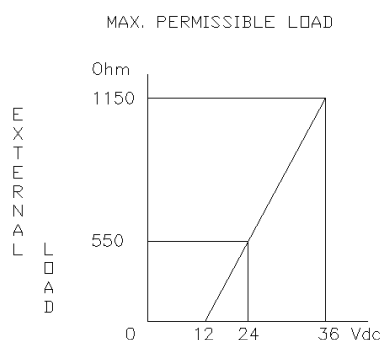

The maximum permissible load (Ri max.) in case of 24 Vdc is 550 Ω (Ohm).

By increasing the power supply, the external load can be increased to 1150 Ohm / 36 Vdc. (see figure left).

$$Ri \text{ max.} = \frac{\text{Power Supply} - 13 \text{ Vdc}(\text{min. power supply})}{20 \text{ mA}}$$



With a loop resistance of 250 Ω a power supply of at least 17 Vdc must be used.

5 Labeling

The label with the serial number and type designation is located on the outside of the housing. The materials identifier is encoded in the type designation.

PRESSURE TRANSMITTER:	
Supply: 13 - 36 V dc	Output: 4 - 20 mA
Span: min. 0 -	max. 0 -
Cal.:	Serial no.:
Ashcroft Instruments GmbH Max-Planck-Str. 1 D 52499 Baesweiler Tel: 0049 (0) 2401-808-0	
CE	

6 Construction and function

The BRONZE SERIES transmitters are solid-state pressure and level transmitters based upon a bridge resistive silicon sensor, with a very high burst pressure. The sensor element is mounted in a stainless steel foot. A strong stainless steel flush diaphragm protects the sensor from the process medium. Special oil fills the chamber surrounding the sensor and transfers pressure from the flush mounted diaphragm to the sensor.

Pressure on the sensor element creates a very small deflection of the silicon substrate and bridge network. The resulting strain in the silicon resistors causes a change in the bridge resistance that is proportional to the pressure applied. The transmitter electronics detects this change in bridge resistance and converts it into 4-20 mA. The amplifier system is based on a single Integrated Circuit, which ensures a perfect linearity in the 4-20 mA output. The electronics are fully encapsulated and are there for unaffected by vibrations and moisture.

6.1 Process transmitter BRONZE SERIES PB55

The BRONZE SERIES PB55 are specially designed for the pulp- and paper or similar industries, where clogging is a problem. The very compact construction of the PB55 permits flush installation with the tank- or pipe wall. Standard the wetted parts are made of St.St. 316, a lot of other materials like Hastelloy C are available as an option.

All transmitters are fully temperature compensated, which means that various process temperatures have nearly no effect on the accuracy of the output signal. When a failure occurs, the transmitter is repairable. However, for optimum accuracy the transmitter has to be send back to the factory.

DIMENSIONAL DRAWING PB55

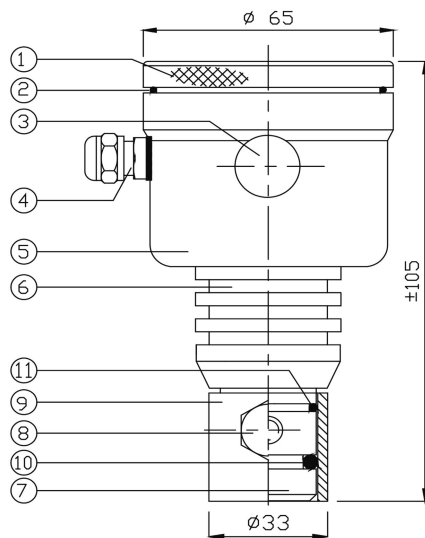

PARTS DESCRIPTION

MATERIAL

- | | | |
|-----|---------------------|--------------|
| 1. | Cover | St.St. 304 |
| 2. | O-Ring | EPDM |
| 3. | Venting | |
| 4. | PG9 Cable Gland | |
| 5. | Electronics housing | St.St. 304 |
| 6. | Cooling fins | St.St. 304 |
| 7. | Diaphragm and ring | St.St. 316 |
| 8. | M8 bolt | St.St. 304 |
| 9. | Weld-on nipple | St.St. 316 L |
| 10. | O-ring | Viton |
| 11. | O-ring | Viton |

6.2 Cleanline transmitter BRONZE SERIES CB55

The BRONZE SERIES CB55 are specially designed with a flush mounted diaphragm so the fully meet the needs of the food, pharma and chemical industries.

Standard the wetted parts are made of St.St. 316, other materials are available, like Hastelloy C. Various process connections can be delivered, such as Tri-Clamp (1.5" ,2" and 3"), SMS (1.5" and 2"), dairy milk couplings (DN 25, 40 and 50), flanges (DIN and ANSI) and sanitary weld-on nipples (ø 48, 62 and 85 mm.)

DIMENSIONAL DRAWING CB55

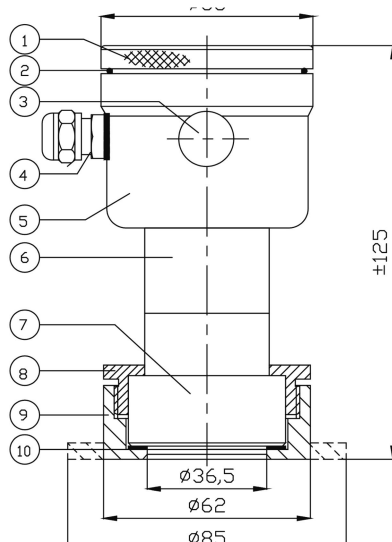

PARTS DESCRIPTION

MATERIAL

- | | | |
|-----|---------------------|--------------|
| 1. | Cover | St.St. 304 |
| 2. | O-Ring | EPDM |
| 3. | Venting | |
| 4. | PG9 Cable Gland | |
| 5. | Electronics housing | St.St. 304 |
| 6. | Foot | St.St. 304 |
| 7. | Diaphragm and ring | St.St. 316 |
| 8. | Lock ring | St.St. 304 |
| 9. | Weld-on nipple | St.St. 316 L |
| 10. | Packing | PTFE |

6.3 Barometric reference

The BRONZE SERIES is in basic a so-called "relative transmitter" which means that barometric changes will not affect the zero (4 mA). The venting is placed in the cover of the electronic housing and is the barometric reference to atmospheric pressure. The venting must be kept clean.

6.4 Accessories

Please contact the manufacturer regarding special tools and accessories.

7 Transport

7.1 Safety

The device should be protected against the effects of knocks and impacts. The device should only be transported in the packaging provided, to protect against damage. The device should only be transported in a clean condition (free of residues of measuring media).

7.2 Transport inspection

The delivery must be checked for completeness and damage during transport. In the event of damage during transport, the delivery must not be accepted, or only accepted subject to reservation of the scope of the damage being recorded and, if necessary, a complaint initiated.

7.3 Storage

The device must be stored in dry, clean conditions, within a temperature range of -20 to +70 °C, protected against direct exposure to sunlight and protected against impact damage.

8 Assembly/Installation

The diaphragm of the transmitter is protected with a special protection cap. Protect the diaphragm until installation takes place. * DO NOT DAMAGE THE DIAPHRAGM. *

8.1 Installing Weld-On Nipple

A certified welder should perform installation of the weld-on nipple. Weld with Argon, MIG or TIG. The smallest welding pin should be used.

1. Cut a hole in the process vessel/pipe to accept the weld-on nipple. The hole should produce a tight fit when coupled with the weld-on nipple.
2. Prepare the hole by beveling the edge to accept filler material.
3. Remove the weld-on nipple from the transmitter.
4. Remove the PTFE packing of the Cleanline transmitter BRONZE SERIES CB55
5. **Remove the gasket and O-ring out of the weld-on nipple!**

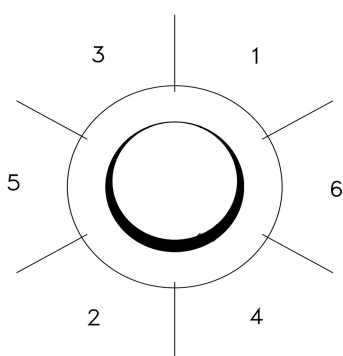

Improper installation may result in distortion of the weld-on nipple. Excessive heat will distort the weld-on nipple. Weld in sections as shown in the figure left. Allow adequate cooling between passes. **To reduce the chances of distortion to the weld-on nipple, use a mandrel.**

(PB55 Part.no. 1016)
(CB55 Part.no. 1019)

Determine (before welding) the position of the electronic housing, so that the cable entry and the venting are in the right position. After welding these positions are fixed.

6. Position the weld-on nipple in the vessel hole and tack six places. The weld sequence is shown in the figure above.
7. Weld the weld-on nipple in place using 0,03 to 0,045 in. (0,762 to 1,143 mm) stainless rod as filler material in the beveled area. Adjust amperage for penetration.
8. Remove the mandrel after the welding operation.

8.2 Installing Process Transmitter BRONZE SERIES PB55 (with weld-on nipple)

1. After welding, clean up edges, and take care of the inside nipple wall.
2. Make sure the O-rings (10) and (11) are properly located. Improper installation at the O-ring can cause a process leak.
3. Apply silicone grease to the O-ring(10), diaphragm ring and the hole inside wall of the weld-on nipple, this prevents galvanic cell corrosion between transmitter and nipple inside.
4. Install the transmitter and fix it with the St.St. M8 bolt.

8.3 Installing Cleanline Transmitter BRONZE SERIES CB55 (with weld-on nipple)

1. Make sure to correctly locate the packing within the weld-on nipple.

2. Improper installation of the packing can cause a process leak.
3. Position the transmitter into the weld-on nipple and begin engaging threads. The transmitter can be rotated prior to seating enabling the user to optimize access to calibration adjustments, cable entry, and local indicator.
4. Once the Lock ring (8) has been hand tightened, it must be tightened with an additional turn with adjustable pliers ($\pm 1/8"$).

8.4 Mounting Position

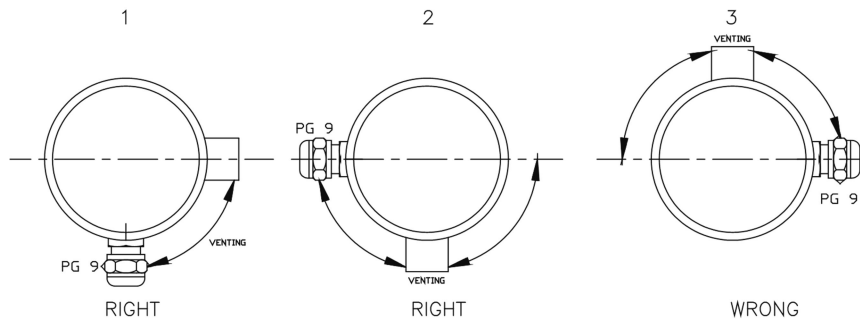

When the transmitter is mounted horizontal, the venting **MUST** be pointed horizontal to downwards. See figure left.

- 1 = Right (= Preferred Position)
- 2 = Right

All other mounting positions are **NOT** allowed (3 = Wrong).

8.5 Mounting Position Effect

The transmitters are calibrated in horizontal position.

If the transmitter is mounted vertical (up or down), there will be a zero shift.

If the transmitter is mounted up there is a small zero shift (< 4 mA).

If the transmitter is mounted down there is a small zero shift (> 4 mA).

After installation of the transmitter the zero must be set at 4 mA with the zero potentiometer.

DO NOT change the span.

8.6 Calibration

All transmitters are fully calibrated at the factory, to the conditions stipulated in users order. When the buyer has not requested calibration, the transmitter will be calibrated at the lowest span.

It may be advisable to recalibrate the transmitter after shipment.

The calibration sequence is as follows:

1. The output of the transmitter must be set at 4 mA (Zero-potentiometer).
2. Air pressure in accordance with the process pressure must be put on the test nipple.
3. The output of the transmitter must be set at 20 mA (Span-potentiometer).
4. Remove the air pressure.
5. Check if the output of the transmitter is 4 mA. (Otherwise repeat steps 1 till 4)
6. Install transmitter (See above).
7. The output must be set at 4 mA (dependable of mounting position)

8.7 Wiring

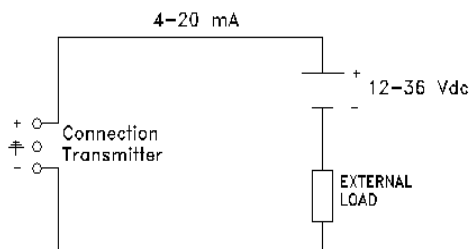

The connector, and zero / span potentiometers are under the cover. Test nipples for calibration of the BRONZE SERIES are available on request.

External loads must be placed in the negative side of the 2-wire loop.

The figure left shows the wiring connection of the transmitter. The 2-wires must be connected to connectors 3 (-) and 4 (+) of the terminal board.

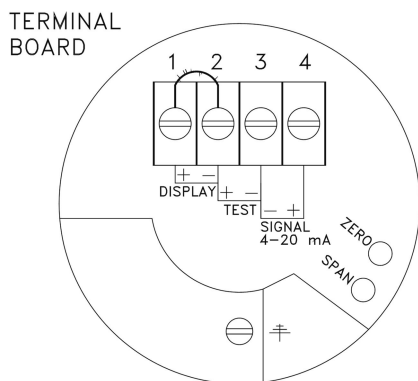

The transmitter must always be connected to earth.

The transmitter must be connected with standard two-wire shielded cable. **DO NOT** run signal wiring in open trays with power wiring, or near "heavy" electrical equipment (E.g. Frequency controllers or heavy pumps). Shielding must always be connected at the side of the power supply. In case the mounting position is already connected to ground (e.g. via the tank or pipe line) do NOT connect the instrument to ground. **Please ensure that the instrument is not connected to ground twice to prevent the occurrence of an 'earth loop'.**

Reversing the polarity will not damage the transmitter, but the transmitter will not function until the + and – are properly connected.

8.8 Digital local indicator(optional)

This intelligent 2-wire loop powered LCD digital display for the BRONZE SERIES transmitters, has a 16 Bit ADC MCU inside. The local indicator displays a digital value that is proportional to the pressure measured by the transmitter. The full scale point may be set to any value between 0000 and 1999. You can use the three buttons to program the zero point, span, unit, decimal point, and damping. The following are the features:

- High accuracy and stability
- 16 Bit ADC MCU inside
- The range of values which can be displayed on the LCD is -1.9.9.9.9.~ 9.9.9.9.9.
- LCD can work at 3mA. Dropout voltage=3.1V
- 34 optional units. Many kinds of values can be displayed such as pressure, temperature etc.
- Friendly soft interface.

The local indicator can be mounted afterwards.

Remove the bridge which is placed between connector (1) and (2). Connect the red (+) wire to (1) and the black (-) wire to (2). When using a local indicator the minimum power supply must be **15.5 Vdc**.

Getting access to the indicator



Unscrew the cover to get access to the push buttons of the display. The display can be turned max. 180° to put it in the desired position for reading. The complete display unit can be taken out to be able to adjust the transmitter. Be careful when taking out the display as the length of the wiring is limited. Please ensure that the cover is fastened properly after adjusting the display to ensure the sealing of the housing.

Setting

- "M" menu item for setting
- "←" to move the cursor
- "↑" to change the value where the cursor points to and move the decimal point

Power on

After the digital LCD display has been connected to the current circle 4~20mA, the LCD is lighted, the initial screen displays the default settings:



Zero-point (value to be displayed for 4mA)

Press button “M” to enter zero-point setting mode: (Factory default setting is 4.0000mA)



- Press “←” to move the cursor.
- Press “↑” to change the value where the cursor points to.
- When the cursor moves to the first number on the left, press “←” again, the decimal point is twinkling, press “↑” to move the decimal point.
- Press “M” to confirm setting and return to the menu item.

Span (value to be displayed for 20mA)

Press “M” to continue, span setting mode is displayed: (Factory default setting 20.000mA)



- Press “←” to move the cursor.
- Press “↑” to change the value where the cursor points to.
- When the cursor moves to the first number on the left, press “←” again, the decimal point will twinkle, press “↑” to move the decimal point.
- Press “M” to confirm setting and return to the menu item.

Unit setting

Press button “M” to continue, unit setting mode is displayed:

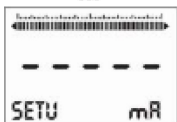

Press “←” or “↑” to select the unit, for example “°C” is selected,



Unit is displayed on the LCD.

Optional units:

mA, V, mV, bar, mbar, Pa, kPa, MPa, mH2O, mmH2O, cmH2O, mmHg, PSI, Tor, kg, g, N, kN, °C, °F, °K, RH, VOL, ppm, LEL, pH, m, cm, mm, Inch, m/s, Ohm, kohm, %

Decimal digits

Press button “M” to continue, decimal digits setting mode is displayed:



Press “←” or “↑” to select the number of decimal digits, (Valid numbers: 0,1,2,3)

Damping

Press button “M” to continue, damping setting model is displayed:



- Press “←” to move the cursor.
- Press “↑” to change the value where the cursor points to. Value is increased and decreased by steps 0.1s. (Min=0s, Max=99.9s, step 0.1s)
- Press “M” to confirm setting and return to the menu item.

Display Mode

Press button “M” to continue, display mode setting is displayed:

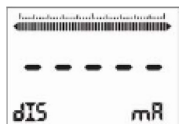

Three display modes can be selected: Pressure, Current or Percentage

Error codes

- Err 2 - Loop current less than 3.6 mA
- Err 3 - Loop current more than 22.8 mA
- Err 4 - AD low
- Err 5 - AD high

8.9 Subsequent relocation of the transmitter (by the customer)



Recommendation: Do not remove the transmitter from one metering point and fit it in a different place, as there is a risk of the measuring media being mixed, with unforeseeable chemical reactions.

9 Servicing

The device is maintenance-free. However, to ensure reliable operation and a long lifetime for the device, we recommend that it is checked regularly

9.1 Safety

When undertaking servicing work on the device, the pressure lines must be depressurized, the electrical connections isolated from the mains supply, and the plant secured against being switched on again.

9.2 Check on function, and recalibration

The check on function and recalibration is carried out at regular intervals, depending on the application. The precise testing cycles should be adjusted in line with the operating conditions and ambient conditions. In the event of various device components interacting, the operating instructions for all other devices should also be taken into account.

- Check on display.
- Check on function, in conjunction with downstream components.
- Check of pressurized connection pipes for seal condition.
- Check of electrical connections.

9.3 Cleaning and maintenance

Cleaning is carried out using a non-aggressive cleaning agent, with the ventilation valve closed and respecting the protection category of the device.

10 Faults

10.1 Safety

Defective or faulty pressure transmitters put the operational safety and process safety of the plant at risk, and can lead to a risk or injury to persons, the environment or the plant.

10.2 Conduct in the event of faults

All defective or faulty devices must be taken out of service. If a repair is required, the device must be sent directly to our Repairs Department. We request that all returns of devices are agreed with our Service Department.

10.3 Fault table

Possible situations indicating a fault:

- No output signal

- Wrong output signal
- Cracked parts
- Indications that the measurement system seal is damaged (process media within the transducer)
- Damage to housing
- Humidity inside the transmitter (wrong sealing of termination)

In these instances, replacement of the pressure transmitter is always required.

10.4 Conduct following fault rectification

See Section 8 Mounting and Installation.

11 Removal, disposal

11.1 Safety



Residues of measuring media in and on removed transmitters can constitute a risk to people, the environment and equipment. Adequate precautionary measures must be adopted. If necessary, the devices must be cleaned thoroughly (see advice in safety data sheets).

11.2 Removal

- When undertaking servicing work on the device, the pressure lines must be depressurized, the electrical connections isolated from the mains supply, and the plant secured against being switched on again.
- Demount the transmitter using a suitable tool

11.3 Disposal



Please help to protect the environment and dispose of or recycle the devices and components used in accordance with the applicable regulations.

12 Appendix

12.1 Data sheet for BRONZE SERIES PB55 and CB55

Detailed data sheet is available from supplier's website (see 1.7 Manufacturer's address, customer services)

This Table refers to specific documents:

Model	Description	Document
PB55/CB55	Stainless steel pressure transmitter BRONZE SERIES	G5.PB55-CB55 EN

12.2 Declaration of conformity model PB55 and CB55